

Total Sulfite, SO₂/H₂S Analysis

By Automated Acidification and Coulometric Detection

Applications include: Total sulfites in foods, dissolved SO₂ and H₂S in amine scrubbing solutions, and sulfites in geological materials and wallboard.



The **CM440 Total Sulfite, SO₂/H₂S Analyzer** is a complete analytical system allowing the direct measurement of total sulfites or dissolved SO₂/H₂S in a wide variety of sample matrices and concentrations. Combining a automated, self-contained unit for the acidification of a sample (to evolve SO₂ and/or H₂S), with a highly sensitive SO₂/H₂S detector, the CM440 easily handles solid or liquid samples with concentrations from ppm levels to 100% without user calibration. UIC's analyzers are rugged, accurate and adaptable to most applications. They are used extensively in industrial, research and educational laboratories worldwide. The CM440 system includes the following components pictured above:

CM5014S SO₂ Analyzer

- No user calibration
- Wide, linear dynamic range
- Readability to 0.01 ug Sulfur
- User selectable display units
- Floppy disk drive for archiving data

CM5240 Auto-Acidification Module

- 45 position carousel
- Low dead volume reaction chamber
- Self cleaning
- Post-acidification scrubber for removal of interferences released during sample digestion
- Controlled sample heating

Instrument Capabilities

A major advantage of the CM440 Total Sulfite, SO₂/H₂S Analyzer is the use of coulometric detection. Employing the principles of Faraday's Law, the CM5014S SO₂/H₂S Analyzer automatically measures the absolute mass amount of sulfur dioxide and/or hydrogen sulfide evolved from an acidified sample. No user-calibration is required and linear detection is available from less than 1 ug sulfur to over 10,000 ug sulfur. Using this 100% efficient coulometric process, relative standard deviations of 0.2% or better are common for standard material. For smaller concentrations, an absolute deviation of approximately 1 ug S is typical.

Oxidation times vary with sample type and temperature although 10 to 15 minute analyses are typical.

Principles of Operation

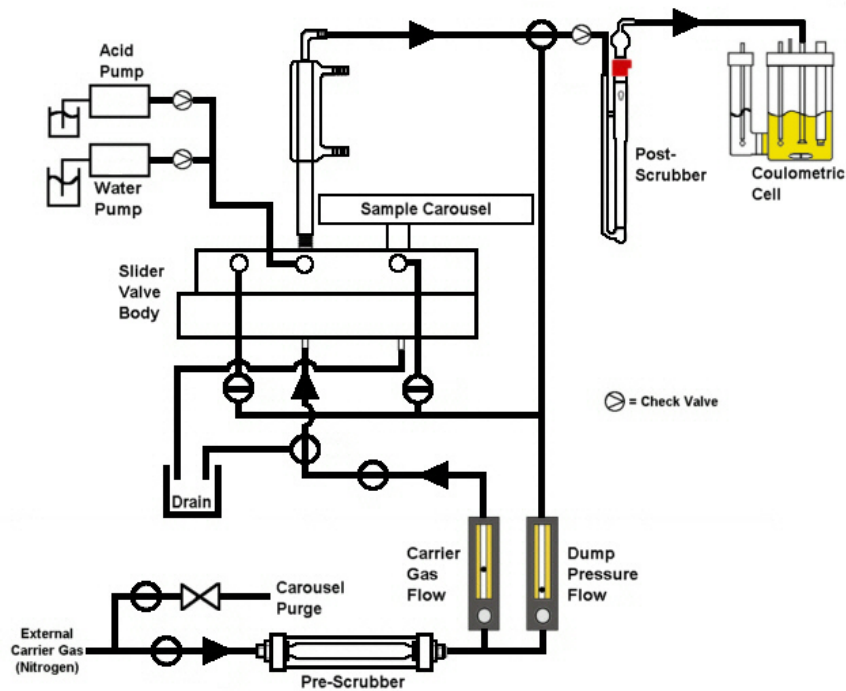

Total Sulfite, $\text{SO}_2/\text{H}_2\text{S}$

Samples are initially weighed into disposable Teflon® cups and loaded into a 45 position sample carousel. As the carousel rotates, each sample drops from the carousel into a small chamber where it is purged with a SO_2 -free carrier gas to eliminate atmospheric interferences. Once purged, the sample moves into the acidification chamber where it is oxidized. A second stream of SO_2 -free carrier gas transports the products of this reaction through a series of post-scrubbers (to remove potential interferences) and ultimately into the reaction cell of a CM5014S SO_2 Analyzer where sulfites evolved as SO_2 are automatically measured using absolute coulometric titration.

Data Handling

Names, weights, volumes or areas of up to 50 samples can be entered, to be used by the CM5014S in calculating the final result. Analytical progress is digitally displayed in user-selectable units. A detailed report is printed while each sample is running that includes the final result. Upon completion of a series of samples, a one page report will print, summarizing the analysis of all 50 samples. The results can also be stored to diskette for further data handling.

Ordering Information

CM440 - Total Sulfite Analyzer

Includes: CM5014S SO_2 Coulometer and CM5230 Auto-Acidification Module with tools and accessories for the analysis of solid or liquid samples. (P/N CM440-01 110V, 50/60Hz) (P/N CM440-02 220V, 50/60Hz)



1225 Channahon Rd., Joliet, IL 60436

PO Box 863 Joliet, IL 60434-0863

800-342-5842 (USA) 815-744-4477 (Illinois)

Email: uicsales@uicinc.com Web: www.uicinc.com